

# Parts Breakdown

## Lexmark C720 Color Laser Printer

**5024-001**

Extracted From Service Manual



**LEXMARK**  
Passion for printing ideas.™

**Edition: December 2002**

**The following paragraph does not apply to any country where such provisions are inconsistent with local law:** LEXMARK INTERNATIONAL, INC. PROVIDES THIS PUBLICATION "AS IS" WITHOUT WARRANTY OF ANY KIND, EITHER EXPRESS OR IMPLIED, INCLUDING, BUT NOT LIMITED TO, THE IMPLIED WARRANTIES OF MERCHANTABILITY OR FITNESS FOR A PARTICULAR PURPOSE. Some states do not allow disclaimer of express or implied warranties in certain transactions; therefore, this statement may not apply to you.

This publication could include technical inaccuracies or typographical errors. Changes are periodically made to the information herein; these changes will be incorporated in later editions. Improvements or changes in the products or the programs described may be made at any time.

Comments may be addressed to Lexmark International, Inc., Department D22A/032-2, 740 West New Circle Road, Lexington, Kentucky 40550, U.S.A or e-mail at [ServiceInfoAndTraining@Lexmark.com](mailto:ServiceInfoAndTraining@Lexmark.com). Lexmark may use or distribute any of the information you supply in any way it believes appropriate without incurring any obligation to you. You can purchase additional copies of publications related to this product by calling 1-800-553-9727. In other countries, contact your point of purchase.

Lexmark, Lexmark with diamond design, MarkNet, and MarkVision are trademarks of Lexmark International, Inc., registered in the United States and/or other countries.

PCL is a registered trademark of the Hewlett-Packard Company.

PostScript is a registered trademark of Adobe Systems Incorporated.

Other trademarks are the property of their respective owners.

**© Copyright Lexmark International, Inc. 2001, 2002.**

**All rights reserved.**

**UNITED STATES GOVERNMENT RESTRICTED RIGHTS**

This software and documentation are provided with RESTRICTED RIGHTS. Use, duplication or disclosure by the Government is subject to restrictions as set forth in subparagraph (c)(1)(ii) of the Rights in Technical Data and Computer Software clause at DFARS 252.227-7013 and in applicable FAR provisions: Lexmark International, Inc., Lexington, KY 40550.

---

## 7. Parts Catalog

---

### How to Use this Parts Catalog

---

- **SIMILAR ASSEMBLIES:** If two assemblies contain a majority of identical parts, they are shown on the same list. Common parts are shown by one index number. Parts peculiar to one or the other of the assemblies are listed separately and identified by description.
- **AR:** (As Required) in the Units column indicates that the quantity is not the same for all machines.
- **NP:** (Non-Procurable) in the Units column indicates that the part is non-procurable and that the individual parts or the next higher assembly should be ordered.
- **NR:** (Not Recommended) in the Units column indicates that the part is procurable but not recommended for field replacement, and that the next higher assembly should be ordered.
- **R:** (Restricted) in the Units column indicates that the part has a restricted availability.
- **NS:** (Not Shown) in the Ref column indicates that the part is procurable but is not pictured in the illustration.
- **PP:** (Parts Packet) in the Description column indicates that the part is contained in a parts packet.
- A part reference within a circle indicates an assembly or a bill-of-material. An assembly is complete. A bill-of-material contains unassembled parts.
- **NA:** Not available/not referenced.

# Assembly 1:

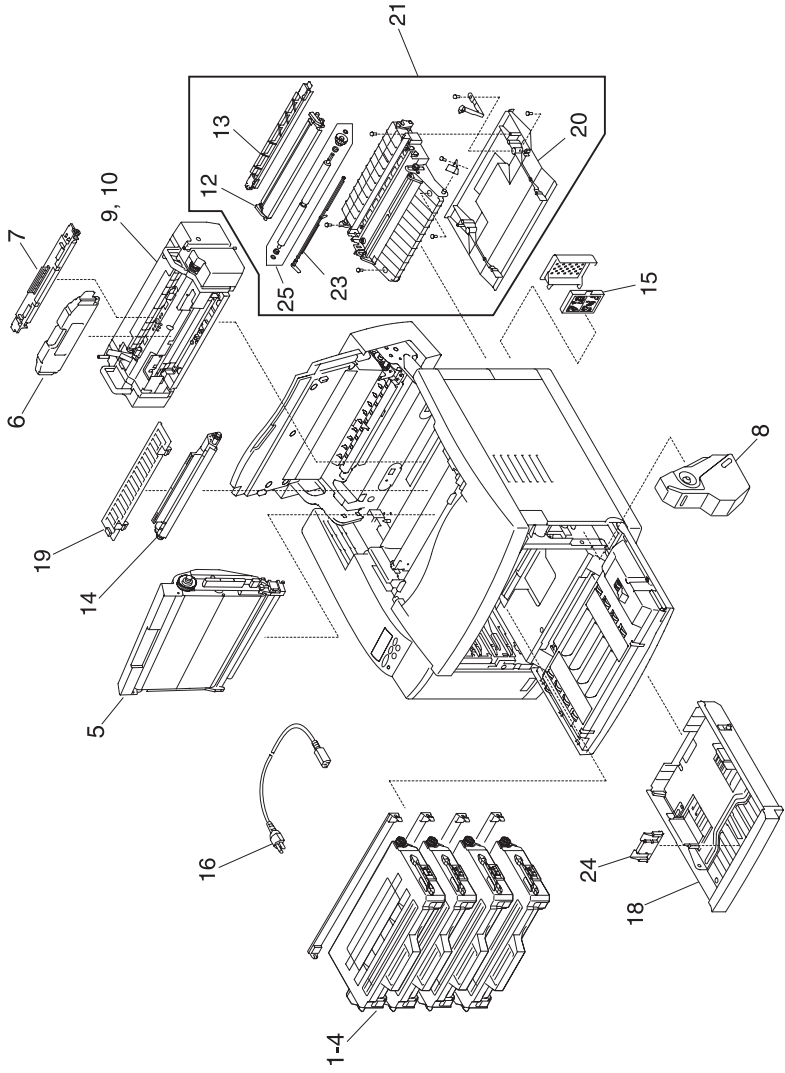

**Assembly 1:**

Ref	Part Number	Units	Description
1 - 1		1	Toner Cartridge -Y (Supply, customer order only)
2		1	Toner Cartridge -M (Supply, customer order only)
3		1	Toner Cartridge -C (Supply, customer order only)
4		1	Toner Cartridge -K (Supply, customer order only)
5		1	OPC Belt Cartridge (Supply, customer order only)
6		1	Fuser Oil Bottle (Supply, customer order only)
7		1	Fuser Cleaner (Supply, customer order only)
8		1	Waste Toner-P (Supply, customer order only)
9		1	Fusing Unit (110V) (Supply, customer order only)
10		1	Fusing Unit (220V) (Supply, customer order only)
12	12G7004	1	Transfer Roller
13	12G7005	1	Paper Discharger
14	12G7006	1	Drum Cleaner
15	12G7007	1	Ozone Filter
16	12G7008	1	Power Cord (U.S.)
16	1339517	1	Power Cord, LV U.S., APG, Bolivia, Canada, Columbia, Costa Rica, Ecuador, EL Salvador, Guatemala, Honduras, Mexico, Nicaragua, Panama, Peru, Venezuela
16	1339518	1	Power Cord, HV, Argentina

# Assembly 1 (cont.):

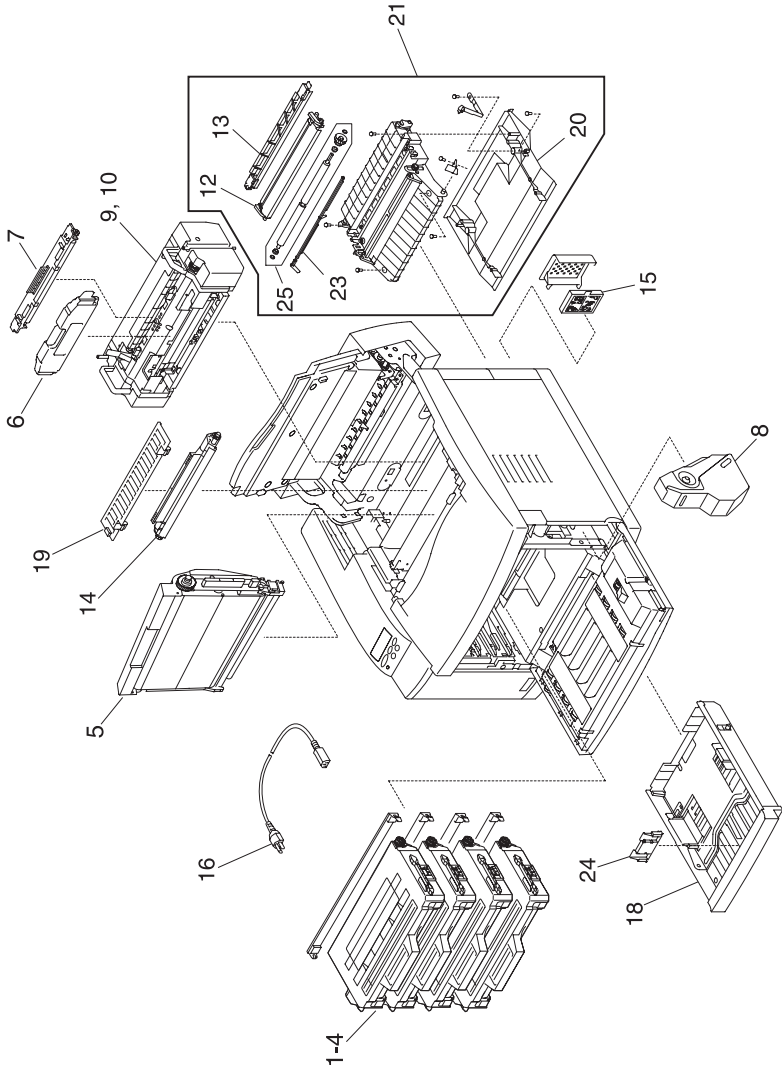

**Assembly 1 (cont.):**

Ref	Part Number	Units	Description
1 - 16	1339520	1	Power Cord, HV, Brazil
16	1339524	1	Power Cord, HV, Chili
16	1339528	1	Power Cord, HV, UK, Ireland
16	1339529	1	Power Cord, HV, Austria, Belgium, EURO English, Finland, France, Germany, Greece, Netherlands, Norway, Poland, Portugal, Russia, Slovakia/Czech/Hungary Spain, Sweden, Turkey
16	1339530	1	Power Cord, HV, Israel
16	1339531	1	Power Cord, HV, Switzerland French, Switzerland German, Switzerland Italian
16	1339532	1	Power Cord, HV, South Africa
16	1339533	1	Power Cord, HV, Italy
16	1339534	1	Power Cord, HV, Denmark
18	12G7010	1	Paper Cassette
18	12G7232	1	Paper Cassette (250 sheet legal)
19	12G7011	1	Cleaner Cover
20	12G7012	1	Transfer Unit Cover
21	12G7013	1	Transfer Unit (includes 12, 13, 20, 23, 25)
23	12G7014	1	PT1 Sensor Lever
24	12G7159	1	Paper Cassette Paper Stop
25	12G7160	1	Registration Roller Assembly
	12G7341	1	Parts Packet, Screws
	12G7340	1	Parts Packet, Cable Clamps, Retainers, Miscellaneous

**Note:** Reference the foldout wiring diagram, in the back of this manual, for cable replacement detailed information. Then go to Assembly 6 for parts ordering information.

# Assembly 2:

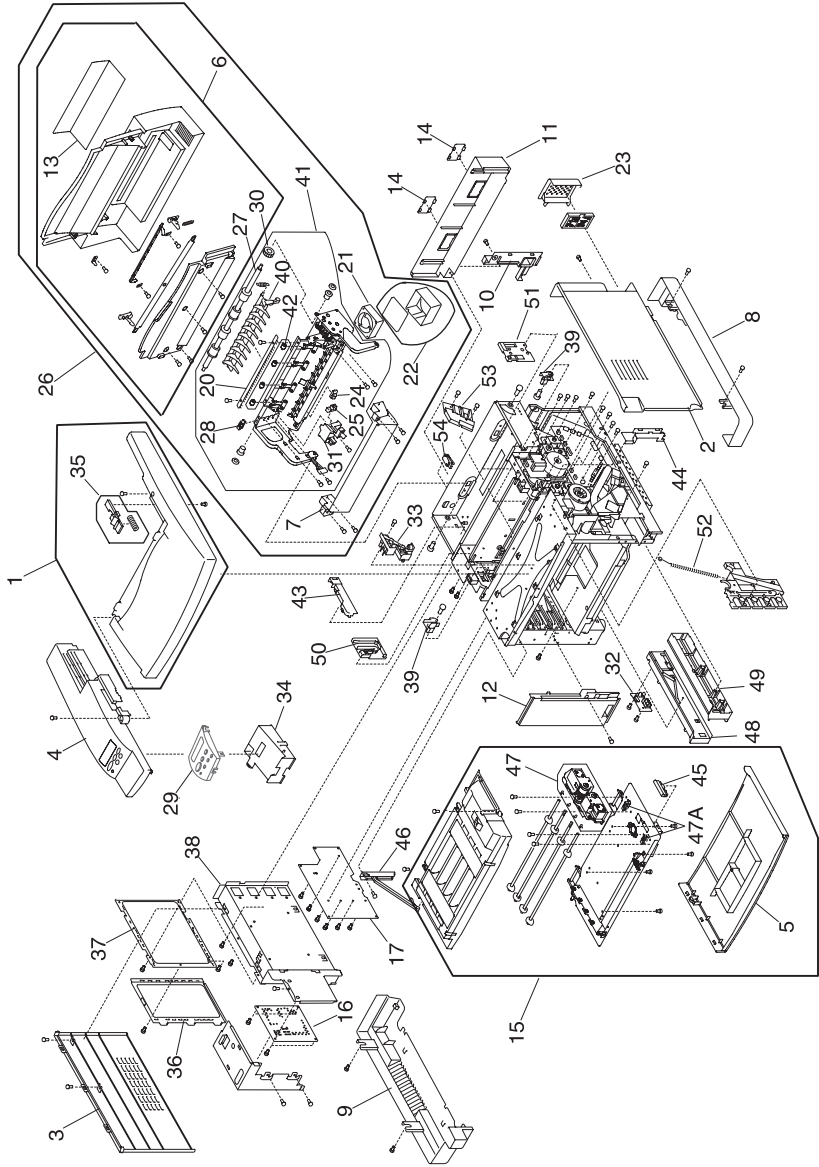



**Assembly 2:**

Ref	Part Number	Units	Description
2 - 1	12G7015	1	Top Cover Assembly (includes 35)
2	12G7016	1	Side Cover (R)
3	12G7017	1	Side Cover (L)
4	12G7018	1	Upper Side Cover (L)
5	12G7019	1	Front Cover
6	12G7020	1	Paper Exit Unit Cover (includes 13)
7	12G7021	1	Paper Exit Front Cover
8	12G7022	1	Base Cover (R)
9	12G7023	1	Base Cover (L)
10	12G7024	1	Rear Cover
11	12G7025	1	Rear Cover (U)
12	12G7026	1	Side F Cover (L)
13	12G7027	1	Paper Exit Upper Cover
14	12G7028	2	Rear Cover (U) Cap
15	12G7029	1	Front Cover Unit (includes 5, 45, 47)
16	12G7030	1	Main Engine (MCTL P.W.B.) Board
17	12G7031	1	High Voltage Unit
20	12G7032	1	Discharge Brush
21	12G7033	1	Cooling Fan (HFAN)
22	12G7034	1	Paper Exit Filter (with Case)
23	12G7035	1	Ozone Filter Cover
24	12G7036	1	Paper Sensor (PT2)
25	12G7037	1	Paper Sensor (FCL)
26	12G7038	1	Paper Exit Unit (includes 6, 7, 13, 20, 21, 22, 24, 25, 27, 28, 30, 31, 40, 42)

# Assembly 2 (cont.):

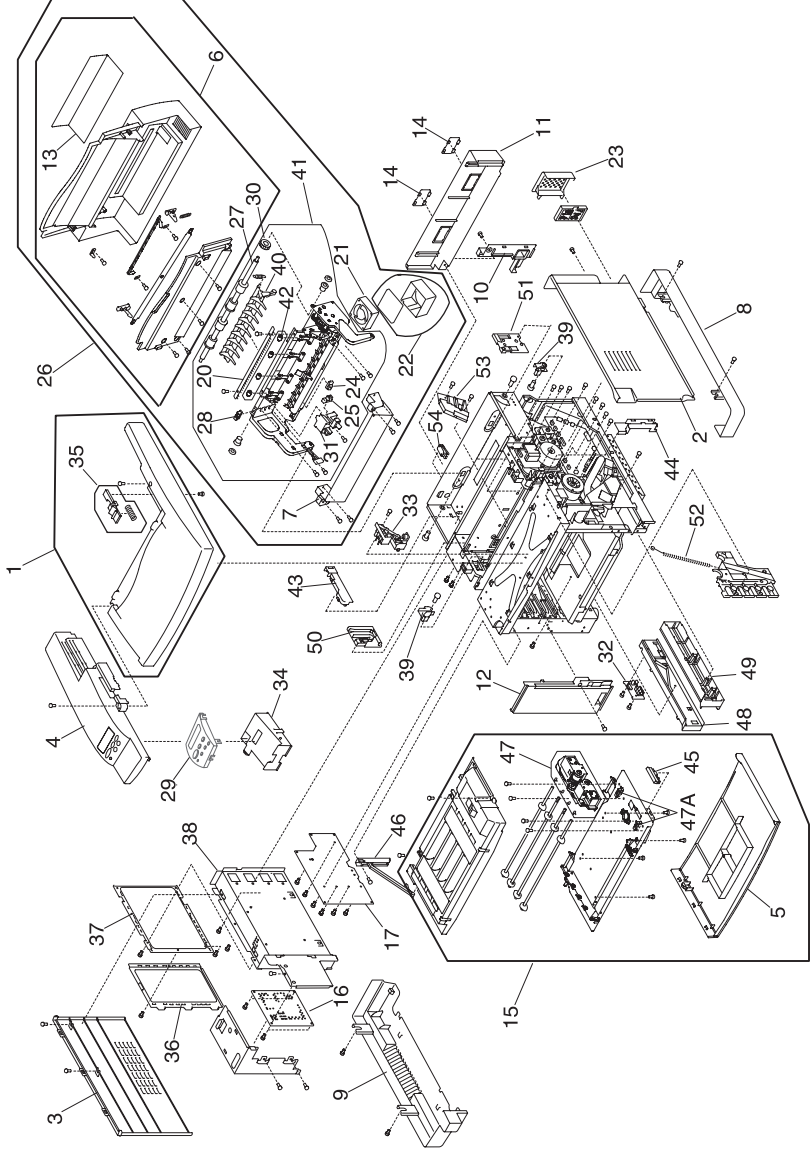

**Assembly 2 (cont.):**

Ref	Part Number	Units	Description
2 - 27	12G7039	1	Paper Exit Roller
28	12G7037	1	Paper sensor (PFUL)
29	12G7360	1	Operator Panel Assembly
30	12G7041	1	Paper Exit Gear Z19
31	12G7042	1	FCS Cover Assembly
32	12G7043	1	Paper Size Sensor
33	12G7044	1	BC Terminal 2
34	12G7161	1	Control Panel Base
35	12G7162	1	Paper Exit Button
36	12G7163	1	Shield Cover B
37	12G7164	1	Shield Cover A
38	12G7165	1	Shield Case Assembly
39	12G7166	1	BC Lock Lever (set)
40	12G7167	1	Paper Exit Switch Guide
41	12G7168	1	Paper Exit Frame Assembly (includes 7,10,24,25,27,28,30,31,40,42)
42	12G7169	1	Paper Exit Idle Roller Set
43	12G7170	1	Paper Exit Harness Cover
44	12G7171	1	IOD Harness Guide
45	12G7172	1	Front Cover Latch
46	12G7173	1	Front Cover/Door Arm Assembly
47	12G7174	1	DE Solenoid Assembly (also order 47A)
47A	12G7036	1	Cam Sensor, DE Solenoid GPH1, GPH2
48	12G7175	1	Front Paper Cassette Guide (L)
49	12G7176	1	Front Paper Cassette Guide (R)

# Assembly 2 (cont.):

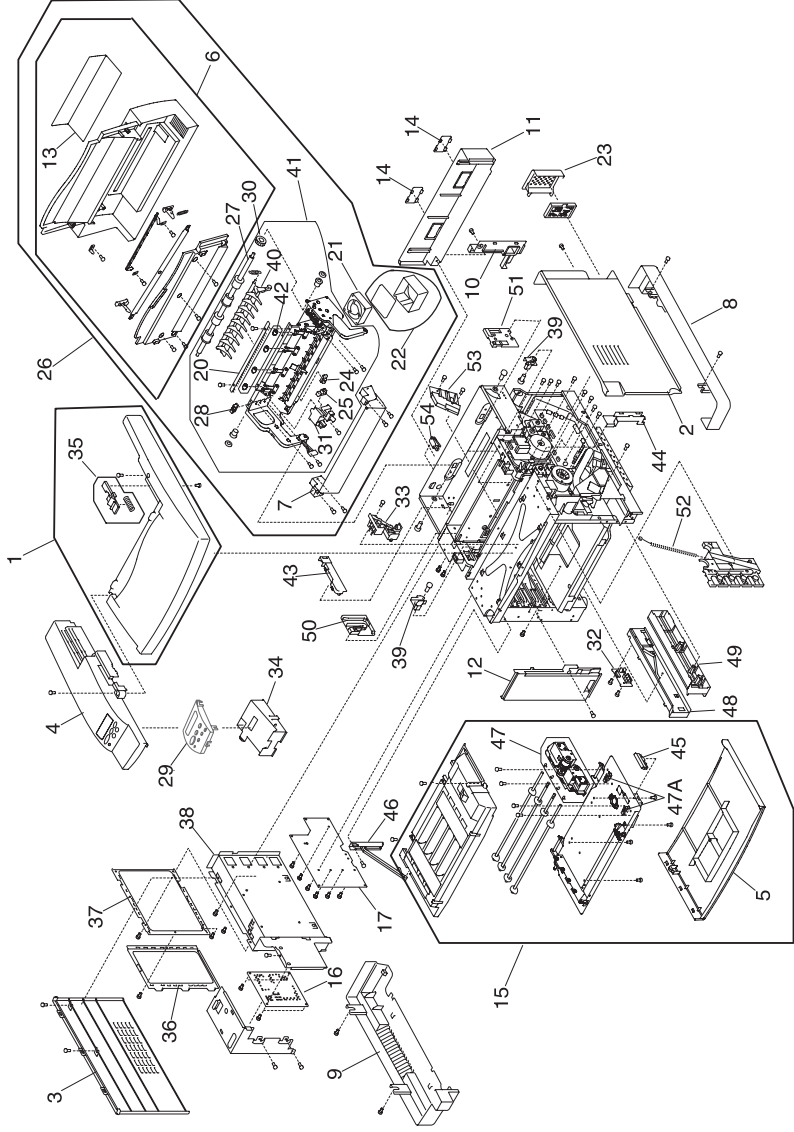

**Assembly 2 (cont.):**

Ref	Part Number	Units	Description
2 - 50	12G7177	1	DC Guide L
51	12G7178	1	DC Guide (R)
52	12G7179	1	Waste Toner U Spring
53	12G7180	1	TR Terminal Base Assembly
54	12G7070	1	Interlock Switch
	12G7341	1	Parts Packet, Screws
	12G7340	1	Parts Packet, Cable Clamps, Retainers, Miscellaneous

**Note:** Reference the foldout wiring diagram, in the back of this manual, for cable replacement detailed information. Then go to Assembly 6 for parts ordering information.

# Assembly 3:

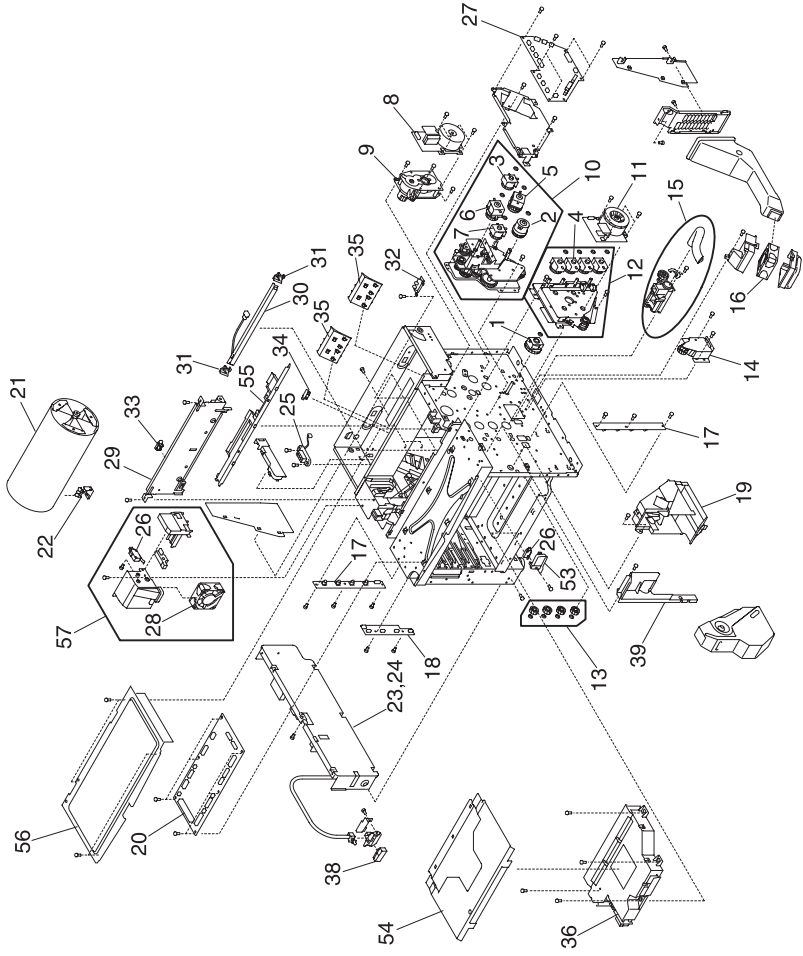

**Assembly 3:**

Ref	Part Number	Units	Description
3 - 1	12G7045	1	Paper Feeding Clutch (PCLU)
2	12G7046	1	Registration Clutch (RECL)
3	12G7047	1	Fuser Clutch (FUCL)
4	12G7048	4	Developer Clutch
5	12G7049	1	Transfer Cam Clutch (TRCM)
6	12G7049	1	Cleaner Cam Clutch (FBCM)
7	12G7051	1	Cleaner Clutch (FBCL)
8	12G7052	1	Main Motor (MM)
9	12G7053	1	BD Gear Assembly
10	12G7054	1	Main Gear Unit (includes 2, 3, 5, 6, 7)
11	12G7055	1	Developer Motor (DM)
12	12G7056	1	Developer Drive Unit (includes 4)
13	12G7057	1	Developer Drive Gear (Set)
14	12G7058	1	FP2 Gear Assembly (Front Developer Solenoid Drive)
15	12G7059	1	Waste Toner Feeder (Lower)
16	12G7060	1	Cooling Fan (OZFAN)
17	12G7061	1	Toner Sensor (TPD, TTR)
18	12G7062	1	Toner Key Sensor (TNK)
19	12G7063	1	Waste Toner Holder Assembly
20	12G7064	1	IOD1 P.W.B.
21	12G7065	1	Transfer Drum
22	12G7037	5	Paper Sensor (Drum Encoder) (HPSEN)
23	12G7067	1	Power Supply Unit (U.S.) 110 V(LVPS)
24	12G7068	1	Power Supply Unit (WT) 220 V (LVPS)

# Assembly 3 (cont.):

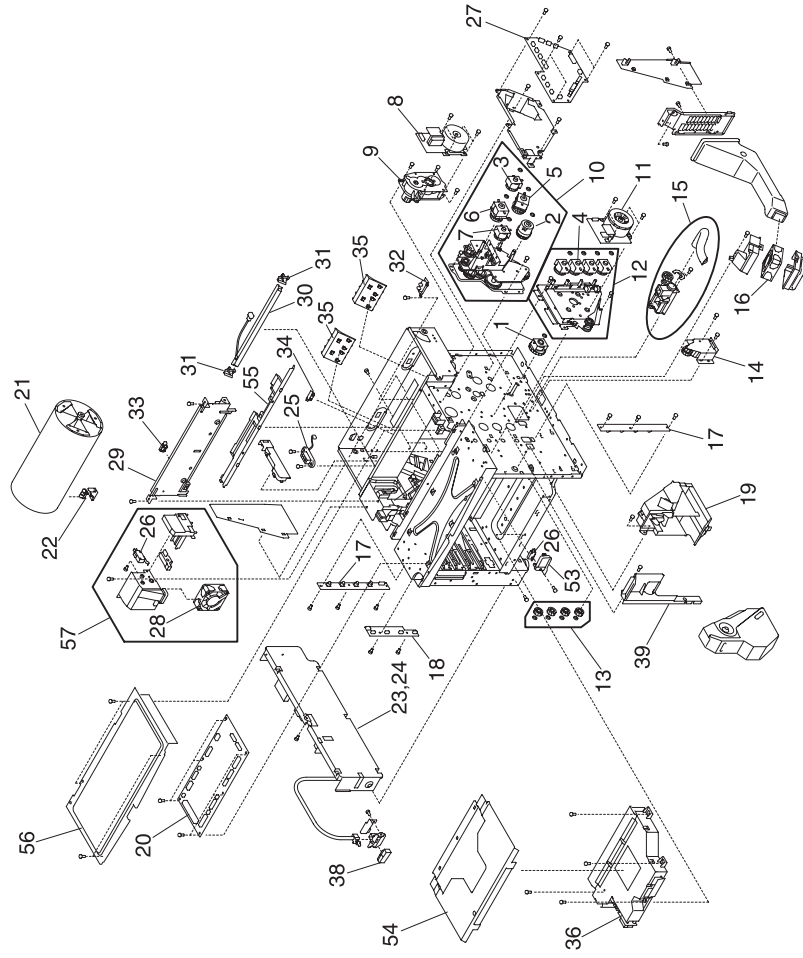



**Assembly 3 (cont.):**

Ref	Part Number	Units	Description
3 - 25	12G7069	1	Fuser Connector
26	12G7070	1	Interlock Switch, Front Door
27	12G7073	1	IOD2 P.W.B.
28	12G7074	1	Cooling Fan (CTFAN)
29	12G7075	1	Waste Toner Feeder Unit (Upper)
30	12G7076	1	Erase Lamp
31	12G7077	2	Erase Holder (2 pieces)
32	12G7078	1	Oil Sensor
33	12G7079	1	Belt Sensor (PBS)
34	12G7079	1	Drum Jam Sensor (DPJ)
35	12G7081	2	Paper Guide D (2 pieces)
36	12G7082	1	Optical Unit (Printhead)
38	12G7083	1	SW Button
39	12G7084	1	Cover (FR)
53	12G7181	1	SW Base Front
54	12G7182	1	Inner Cover C
55	12G7183	1	Oil Sensor Cover
56	12G7184	1	Shield Upper
57	12G7185	1	PS Fan Assembly (CTFAN) (includes 26, 28)
	12G7341	1	Parts Packet, Screws
	12G7340	1	Parts Packet, Cable Clamps, Retainers, Miscellaneous

**Note:** Reference the foldout wiring diagram, in the back of this manual, for cable replacement detailed information. Then go to Assembly 6 for parts ordering information.

## Assembly 4:

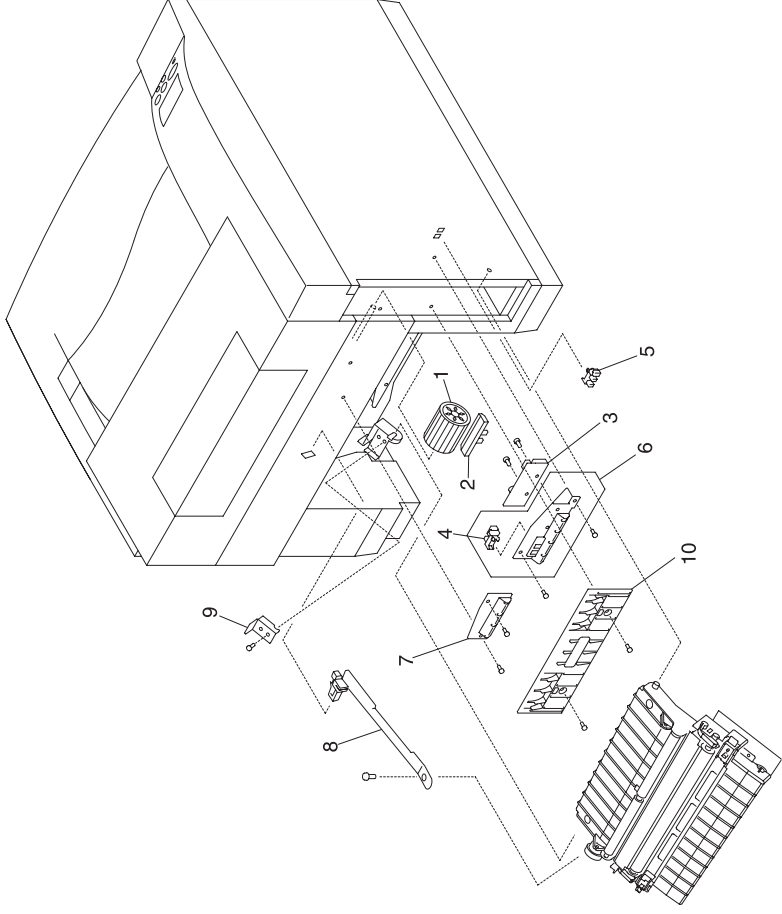

**Assembly 4:**

Ref	Part Number	Units	Description
4 - 1	12G7098	1	Paper Feed Roller
2	12G7099	1	Separator Pad
3	12G7100	1	OHP Sensor
4	12G7037	1	Paper Sensor (PEU)
5	12G7037	1	Paper Sensor (PT1)
6	12G7103	1	Paper Guide (UL) Assembly
7	12G7104	1	Paper Guide (UR)
8	12G7186	1	Transfer Unit Rear Band
9	12G7187	1	Transfer Unit Hinge Support Bracket
10	12G7188	1	Paper Guide L
	12G7341	1	Parts Packet, Screws
	12G7340	1	Parts Packet, Cable Clamps, Retainers, Miscellaneous

**Note:** Reference the foldout wiring diagram, in the back of this manual, for cable replacement detailed information. Then go to Assembly 6 for parts ordering information.

# Assembly 5: Controller RIP Card

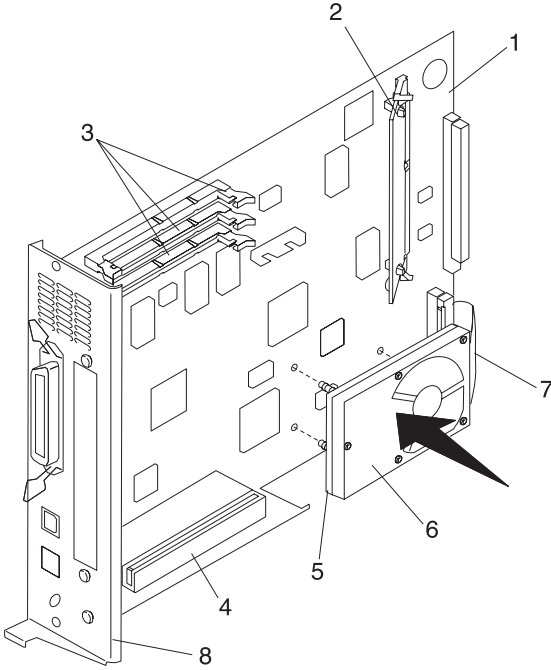

## Assembly 5: Controller RIP Card

Ref	Part Number	Units	Description
5 - 1	12G7226	1	Controller RIP Card Network
1	12G7227	1	Controller RIP Card
2	12G7228	1	SIMM Code
3	99A1752	1	4MB SDRAM DIMM
3	99A1755	1	32MB SDRAM DIMM
4	12G7229	1	Riser Card Assembly
5	12G7231	1	Hard Disk Mounting Bracket
6	99A0459	1	Hard Disk
7	11G0962	1	Hard Disk Cable
8	12G7230	1	Bracket, Controller RIP Card

**Note:** The standard and network models have listed memory. See Assembly 7 for part number information.

# Assembly 6: Printer Cable Harness Sets

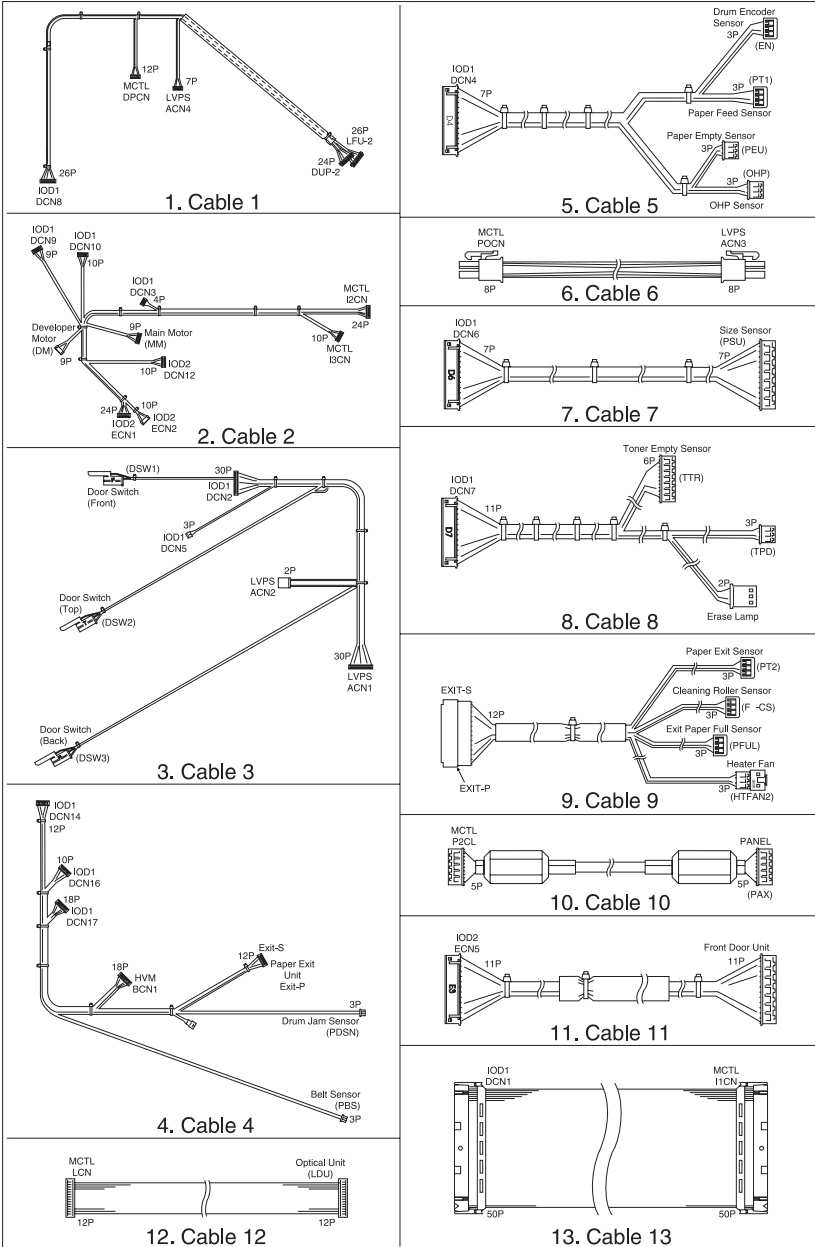

## Assembly 6: Printer Cable Harness Sets

Ref	Part Number	Units	Description
6 - 1	12G7342	1	Harness WH (A) Wiring Diagram #1
2	12G7343	1	Harness WH (B) Wiring Diagram #2
3	12G7344	1	Harness WH (C) Wiring Diagram #3
4	12G7345	1	Harness WH (D) Wiring Diagram #4
5	12G7346	1	Harness WH (I1/SEN) Wiring Diagram #5
6	12G7347	1	Harness WH (LPC) Wiring Diagram #6
7	12G7348	1	Harness WH (SIZE) Wiring Diagram #7
8	12G7349	1	Harness WH (I1/TO) Wiring Diagram #8
9	12G7350	1	Harness WH (PEX) Wiring Diagram #9
10	12G7351	1	Harness WH (LXPN) Wiring Diagram #10
11	12G7352	1	Harness WH (I2/FD) Wiring Diagram #11
12	12G7353	1	Harness WH (DUAL) Wiring Diagram #12
13	12G7354	1	Harness WH (MC/I1) Wiring Diagram #13

**Note:** Reference the foldout wiring diagram, in the back of this manual, for cable replacement detailed information.

5024-001

## **Assembly 7: Miscellaneous**

(No illustration)



**Assembly 7: Miscellaneous**

Ref	Part Number	Units	Description
NS	12G1704	1	Card Assembly, SIMM IPDS/SCS/TNE
NS	13A0297	1	Cable, Coax
NS	13A0296	1	Cable, Twinax
NS	99A0459	1	Hard Disk, 2.1GB
NS	99A0545	1	Adapter, Serial
NS	12G1696	1	MarkNet N2000t 4/16 Token Ring
NS	12G1697	1	MarkNet N2002e 10Base2/10BaseT
NS	99A1830	1	MarkNet N2001e 10/100 Ethernet
NS	99A1752	1	4MB SDRAM DIMM
NS	99A1753	1	8MB SDRAM DIMM
NS	99A1754	1	16MB SDRAM DIMM
NS	99A1755	1	32MB SDRAM DIMM
NS	99A1756	1	64MB SDRAM DIMM
NS	99A1773	1	128MB SDRAM DIMM
NS	99A1757	1	2MB Flash DIMM
NS	99A1758	1	4MB Flash DIMM
NS	99A1759	1	8MB Flash DIMM
NS	99A1774	1	16MB Flash DIMM
NS	99A0560	1	Tri-Port Adapter (Serial/LocalTalk and Infrared)
NS	99A0923	1	Board, USB/Parallel Port
NS	99A0467	1	Board, Parallel Port Adapter
NS			Relocation Packaging
NS	7366394	1	- Base Printer
NS	7366417	1	- Lower Feed Unit
NS	7366413	1	- Duplex Unit
NS	7366409	1	- Base Printer / Duplex bundle

# Assembly 8: Lower Feed Unit

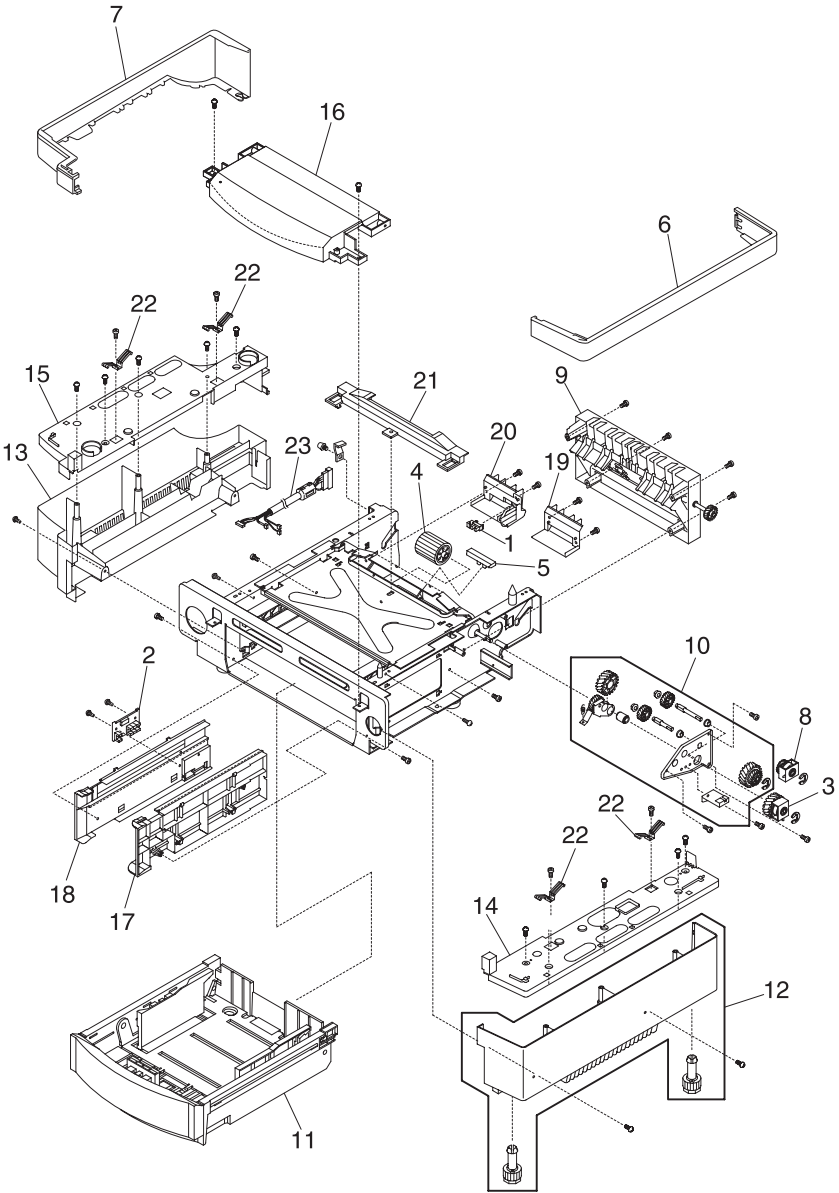

**Assembly 8: Lower Feed Unit**

Ref	Part Number	Units	Description
8 - 1	12G7037	1	Paper Sensor (PEL)
2	12G7043	1	Paper Size Sensor (PSL)
3	12G7045	1	Paper Feed Clutch (PKCL)
4	12G7098	1	Paper Feed Roller
5	12G7099	1	Separator Pad (2)
6	12G7121	1	LF Side Cover R
7	12G7122	1	LF Side Cover L
8	12G7123	1	LF Clutch Drive, Transport Roller (DPKCL)
9	12G7124	1	LF Rear Cover Assembly (includes Transport Roll)
10	12G7144	1	Drive Gear Assembly
11	12G7224	1	LF Paper Feed Cassette
12	12G7145	1	LF Base Cover (R) Assembly
13	12G7146	1	LF Base Cover (L)
14	12G7147	1	LF Top Cover (R)
15	12G7148	1	LF Top Cover (L)
16	12G7149	1	LF Front Top Cover
17	12G7150	1	LF Cassette Guide (R)
18	12G7151	1	LF Cassette Guide (L)
-19	12G7152	1	LF Paper Guide (UR)
20	12G7153	1	LF Paper Guide (UL)
21	12G7154	1	LF Rear Top Cover
22	12G7155	1	GND Contacts
23	12G7156	1	Cable Harness
	12G7135	1	LFU / Duplex Parts Packet, Screws

# Assembly 8 (cont.): Lower Feed Unit (cont.)

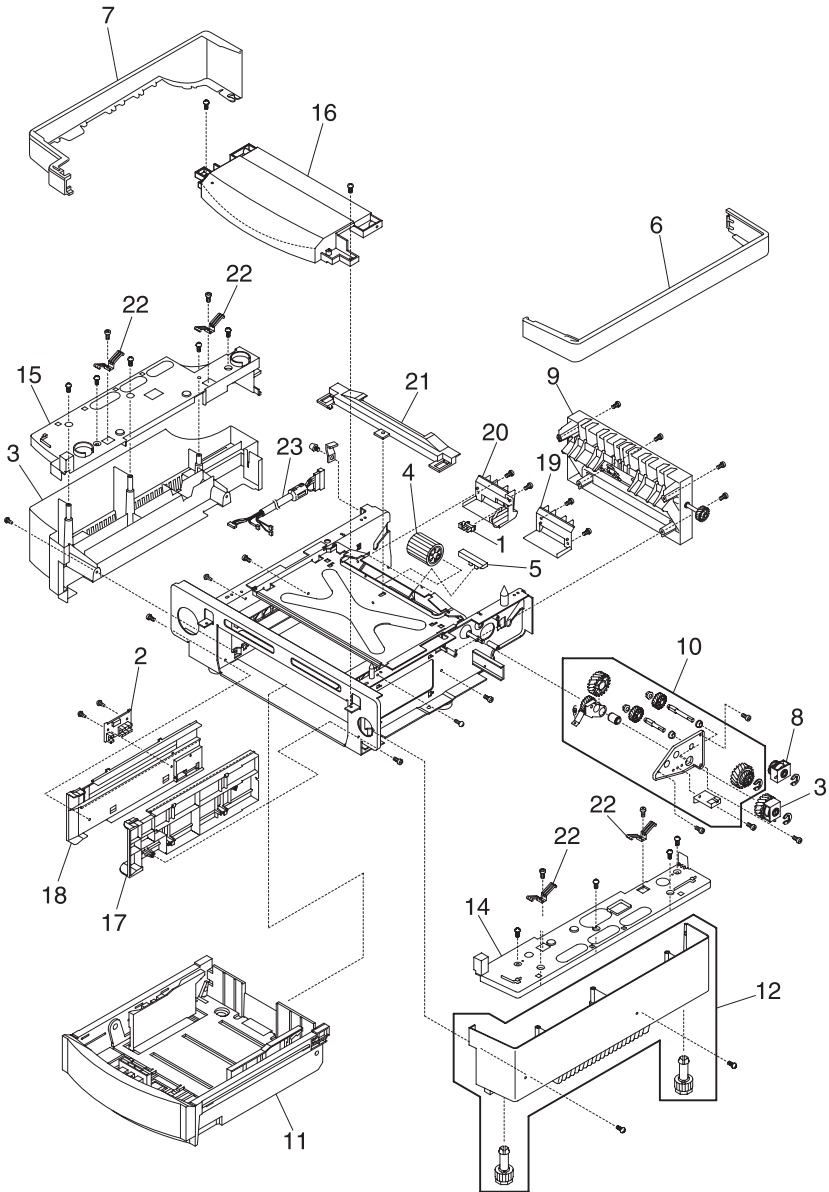

**Assembly 8 (cont.): Lower Feed Unit (cont.)**

Ref	Part Number	Units	Description
	12G7135	1	LFU / Duplex Parts Packet, Screws
	12G7136	1	LFU / Duplex Parts Packet, Retainers
	12G7137	1	LFU / Duplex Parts Packet, Cable Tie / Guides
	12G7139	1	LFU / Duplex Parts Packet, Springs

**Note:** Reference the foldout wiring diagram, in the back of this manual, for cable replacement detailed information. Then go to the assembly for parts ordering information.

# Assembly 9: Duplex Unit

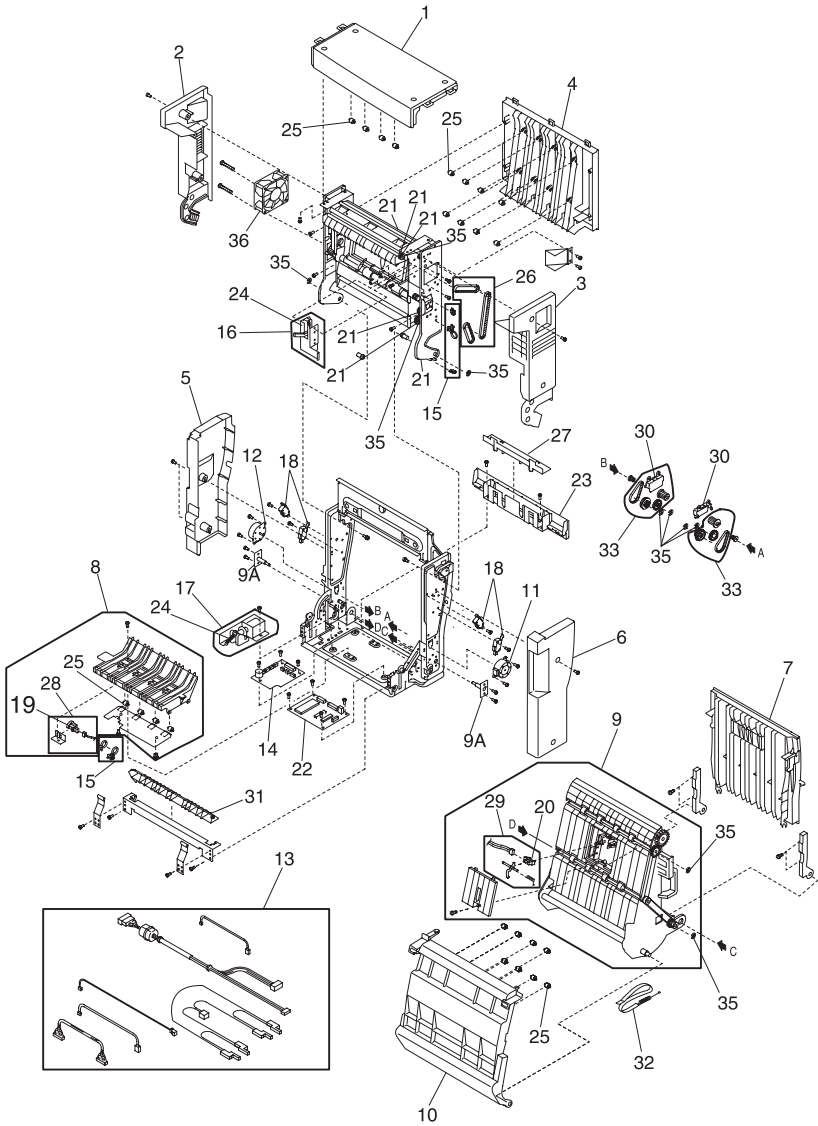

**Assembly 9: Duplex Unit**

Ref	Part Number	Units	Description
9 - 1	12G7105	1	Cover Top (C) Assembly
2	12G7106	1	Cover Top (L)
3	12G7107	1	Cover Top (R)
4	12G7108	1	Cover Top (B) Assembly
5	12G7109	1	Cover Low (L)
6	12G7110	1	Cover Low (R)
7	12G7111	1	Cover Low (B) Assembly
8	12G7112	1	Paper Guide Bottom Assembly (includes 19, 25, 28)
9	12G7113	1	Paper Guide RVS Assembly (includes 20, 29)
10	12G7114	1	Paper Guide Inner
11	12G7115	1	Motor 1(DPM1)
12	12G7116	1	Motor 2 (DPM2)
13	12G7138	1	4 Cable Bill of Material (Door, P.W.B.- P.W.B.,I/F, Solenoid, PT4 P.W.B., Fan)
14	12G7117	1	Relay P.W.B.
16	12G7140	1	Solenoid (U) Assembly
17	12G7141	1	Solenoid (L) Assembly
18	12G7070	4	Interlock Switch (DSW1 - DSW4)
19	12G7143	1	D Sensor (PT4)
20	12G7125	1	D Sensor (PT5)
21	12G7118	1	Paper Guide U Assembly (includes printer reference 26)
22	12G7119	1	DUP P.W.B.

# Assembly 9 (cont.): Duplex Unit (cont.)

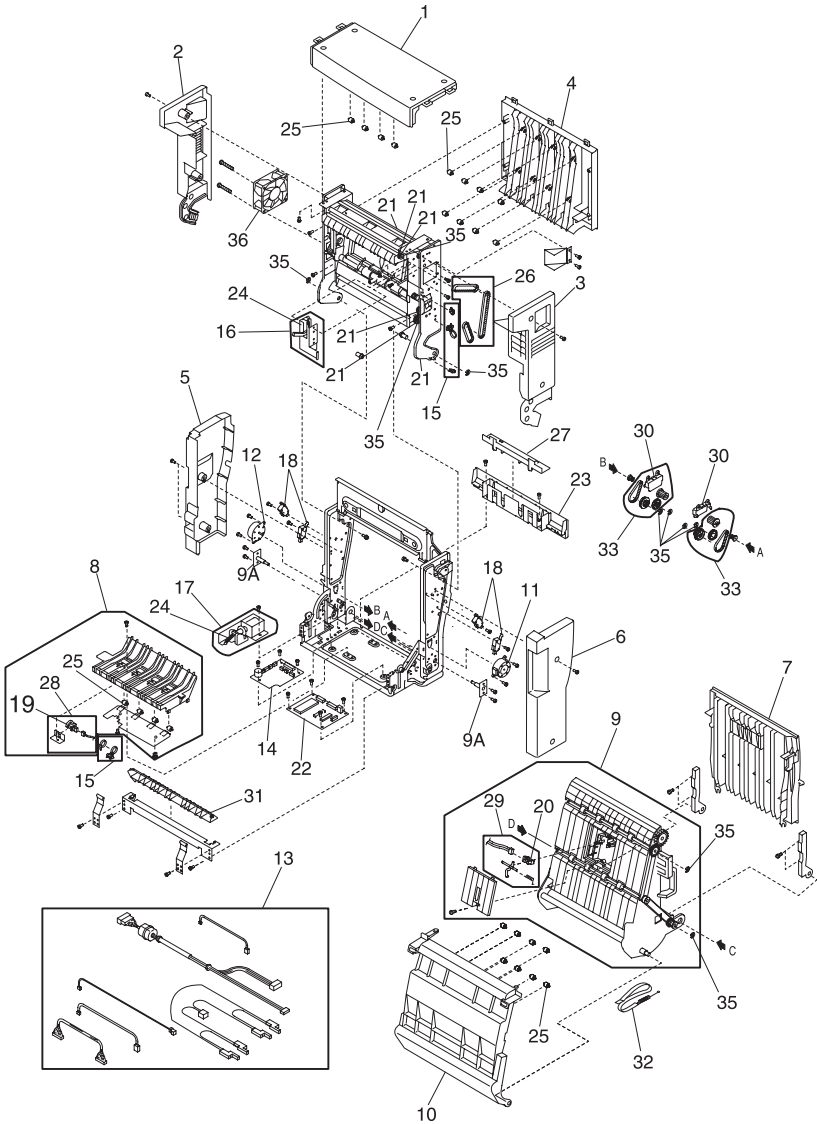



**Assembly 9: Duplex Unit**

Ref	Part Number	Units	Description
9 - 23	12G7120	1	Cover Bottom
24	12G7139	1	Spring (contains 2 springs)
25	12G7126	1	D Roller (contains 20 rollers)
26	12G7127	1	3 Belts
27	12G7128	1	Lid-WH Bottom
28	12G7129	1	D Sensor Bottom Bill of Material
29	12G7130	1	D Sensor Middle Bill of Material
30	12G7131	2	D Gear Cover
31	12G7132	1	Gate Bottom
32	12G7133	1	Band-Spring Set
33	12G7134	2	3 Gears-Belt Set
35	12G7136	1	LFU / Duplex Screw Parts Pack
36	12G7138	1	Fan Motor (DFAN)
	12G7135	1	LFU / Duplex Parts Packet, Screws
	12G7136	1	LFU / Duplex Parts Packet, Retainers
	12G7137	1	LFU / Duplex Parts Packet, Cable Tie / Guides
	12G7139	1	LFU / Duplex Parts Packet, Springs

**Note:** Reference the foldout wiring diagram, in the back of this manual, for cable replacement detailed information. Then go to the assembly for parts ordering information.